

The GENERAL RADIO EXPERIMENTER

VOL. VII. No. 10



MARCH, 1933

ELECTRICAL COMMUNICATIONS TECHNIQUE AND ITS APPLICATIONS IN ALLIED FIELDS

MIXER CIRCUITS THAT WORK

A MIXER circuit is an arrangement of volume controls for combining into one program, in any desired proportions, program elements on several channels. All of the multiple-microphone, transition, and fading effects, which contribute so much to program continuity, are obtained with mixer circuits.

For instance, separate microphones may be used for a soloist and for the accompanying orchestra, and the outputs combined to form a balanced whole. Similarly, separate microphones may be used to pick up the various sections of a large orchestra. Since the volume on each microphone channel can be regulated independently of the others, a method of controlling the balance between the various sections is obtained which, unlike the usual "tone control," does not impair the quality of the individual instruments. A mixer is also used to "fade down" a musical transmission so that announcements or advertising talks may be superimposed. All of these effects contribute a degree of smoothness to a broadcast

program or recording which would otherwise be impossible.

CHOICE OF CIRCUIT

The design of a high-quality mixer is quite simple. The actual choice of a circuit is determined mainly by the number of channels needed and by the impedance requirements of the system. If the mixer is to be used with equipment that is balanced to ground, this factor must also be taken into consideration. Several representative types of mixer circuits are shown in Figures I and II.

NUMBER OF CHANNELS ▲ ▲ ▲ In designing a mixer, it is advisable to allow a separate channel for each available microphone, line, or transcription pickup, thus making it unnecessary to patch circuits while a program is in progress. The cost of an extra volume control is negligible compared with the consequences of even a single program interruption.

IMPEDANCE RELATIONS ▲ ▲ ▲ The volume control used on each channel should have an impedance that matches approximately the equipment with which that channel is to

"EXPERIMENTER" NOW ON BI-MONTHLY SCHEDULE
The next issue will be April-May — In the mails May 15

be used. The three standard impedance ratings (50, 200, and 500 ohms) take care of practically all requirements. It is advisable, although not always necessary (see Figure IIa), to have all of the channel controls alike and to use impedance-matching transformers to couple the mixer to any equipment having a different value of impedance.

When the channel controls are not all of the same impedance, the circuit should be so designed that, as in Figure IIa, the attenuation is approximately equal on all channels.

The mixers shown in Figures I and II have all proven very satisfactory. In the four-channel series-parallel type (Figure IIb), the output impedance of the mixer is equal to the input impedance of each channel. In the series-type mixer (Figures Ia, IIb, and IIc), the output impedance is equal to the sum of the channel impedances, which is frequently an advantage where low-impedance channels are used, since the input impedance of most speech amplifiers is 200 or 500 ohms.

In a series-type mixer of more than two channels, some channels must be above ground potential. Usually this is of no consequence if the equipment connected to these channels is not grounded and the leads are reasonably short. If any noise pickup or crosstalk due to this condition is encountered, however, it may be remedied by using impedance-matching or circuit-isolation transformers on these channels.

Figures IIb and IIc show suggested uses for the above-ground channels in a series mixer. In these diagrams,

channel #1 is equipped with a 500-ohm (or 125-ohm) transformer for coupling to the usual 500-ohm transcription equipment or program line. In Figure IIb a fader is also shown for transferring from one pickup to another. In Figure IIc, channel #4 is also equipped with a 500-ohm transformer for coupling to the usual program transmission lines.

TRANSFORMERS

In the above-mentioned cases the transformers are used both for circuit isolation and for impedance-matching. Transformers may, of course, be used equally well with the channels at ground potential in all of the mixers shown but are not necessary except for impedance-matching, balancing to ground, or keeping direct current out of the mixer.

Figure Id shows how a TYPE 585-C Transformer may be connected to give any one of four impedance ratios. It may be operated with either winding used as the primary, so this one transformer will perform most of the impedance-matching functions usually needed in mixers. It can also be used for circuit isolation purposes when coupling circuits at ground potential to circuits above ground potential and for coupling to 500- or 200-ohm balanced-to-ground circuits.

For isolating two 500-ohm circuits, the TYPE 585-R Transformer should be used. This is a 500-to-500-ohm transformer with both windings center-tapped (for balance to ground, if desired) and with an electrostatic shield between the windings. Similar General Radio transformers for operation at other impedances can also be supplied upon order.

MASTER GAIN CONTROLS

Although a master control is not an absolute necessity, it is a decided convenience where the monitoring operator must manage more than two channels and where considerable ranges of gain must be covered. General Radio TYPE 653 Volume Controls are recommended for mixers in which balance of the output to ground is unimportant. Balanced output circuits require a suitable isolation transformer or a TYPE 552-H Volume Control, balanced-H-type.

CHOOSING VOLUME CONTROLS

In any well-designed mixer the volume on each channel can be adjusted without altering that on the other channels. This is most easily accomplished by using volume controls of the constant-impedance type. Minor changes in impedance will have no noticeable effects upon the operation of the mixer. It is also extremely advisable that the controls be so arranged that a low-attenuation resistance network is still in the circuit when the control is turned to the minimum-loss position. This eliminates the possibility of the mixer

opening up if any of the associated equipment is disconnected while its channel control is in the ON position. Of course each control should be individually shielded to eliminate crosstalk and noise pickup within the mixer itself, and should cut off completely in the OFF position.

Because a mixer is followed by considerable amounts of amplification, only quiet volume controls can be used. The actual quantitative measurement of noise becomes increasingly more difficult as the noise level is reduced and actual figures should be liberally discounted. The determining factor in the selection of any volume control should be its actual performance in service and not mere claims of the manufacturer.

All of these features are combined in the General Radio TYPE 653 Volume Controls. Their impedance is practically constant with setting, their "cutoff" is practically complete, their noise level is below the tube noise level in the best broadcast amplifiers, and they are constructed for long life. We recommend them for every mixer requirement. —H. H. SCOTT

MIXER ACCESSORIES

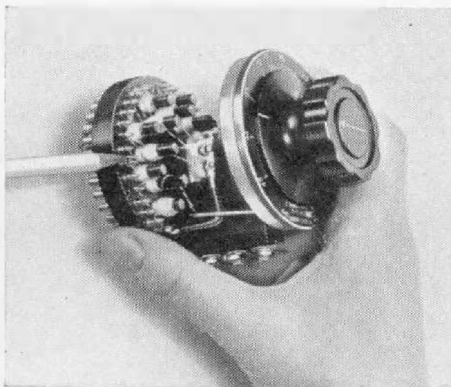

VOLUME CONTROLS
 TYPE 653-MA, 50 ohms
 TYPE 653-MB, 200 ohms
 TYPE 653-MC, 500 ohms
 PRICE: \$12.50

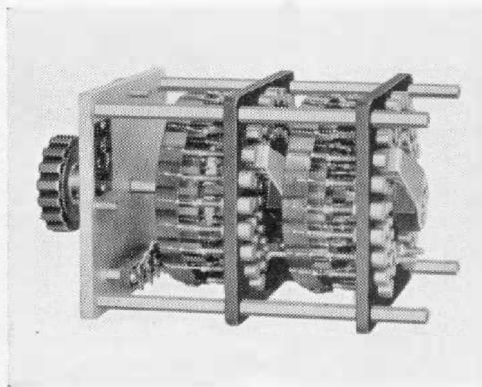

MASTER CONTROLS
 TYPE 552-HB, 200 ohms
 TYPE 552-HC, 500 ohms
 PRICE: \$48.00



TRANSFORMERS
 TYPE 585-C } See
 TYPE 585-R } "Transformers"
 Page 2
 PRICE: \$7.50

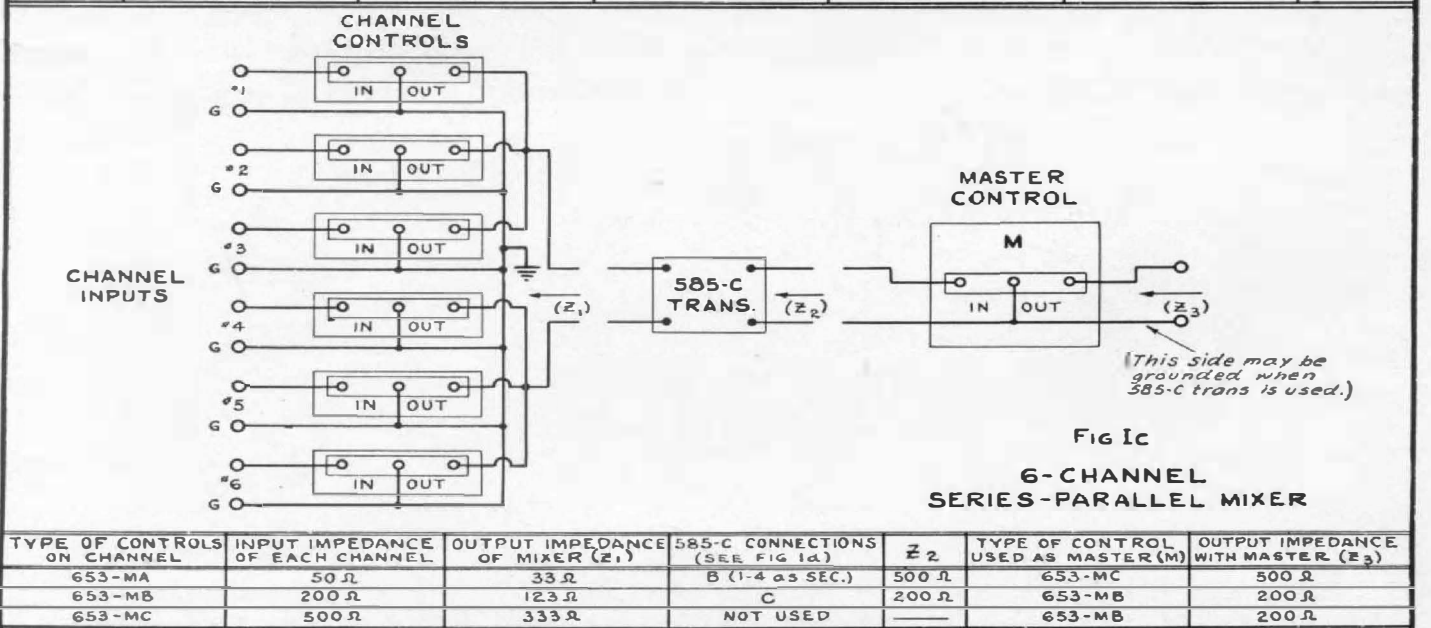
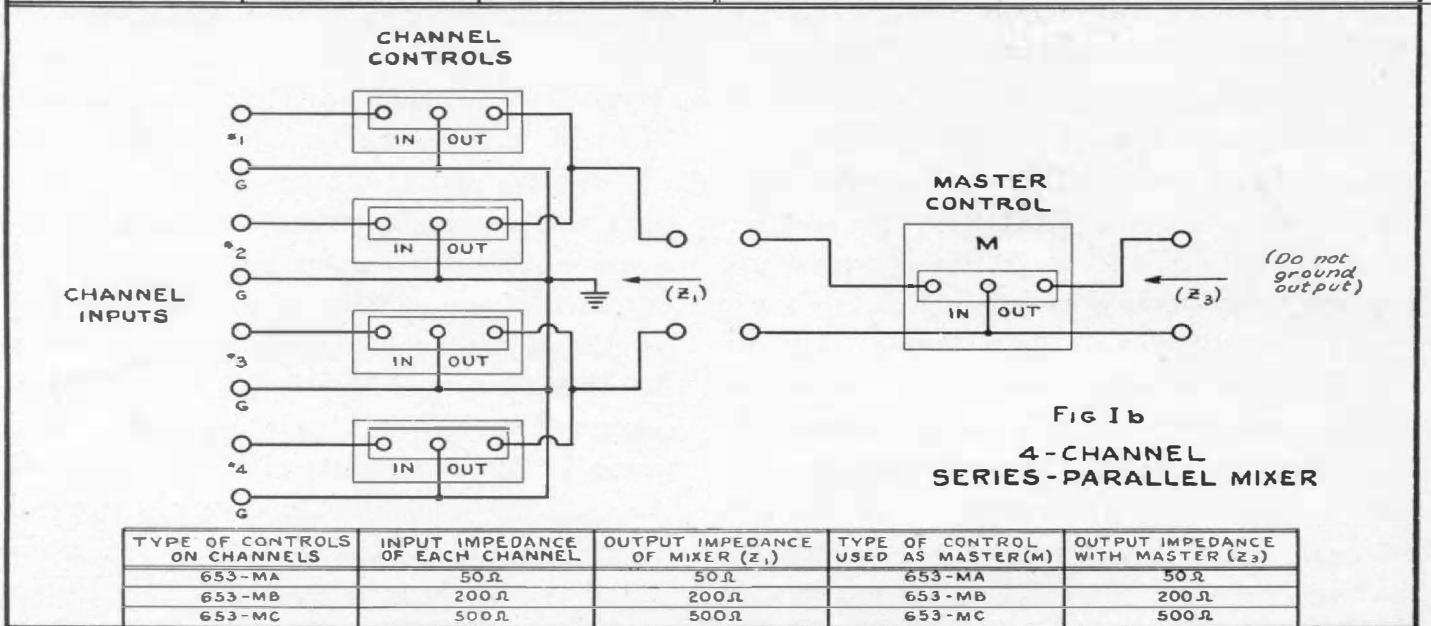
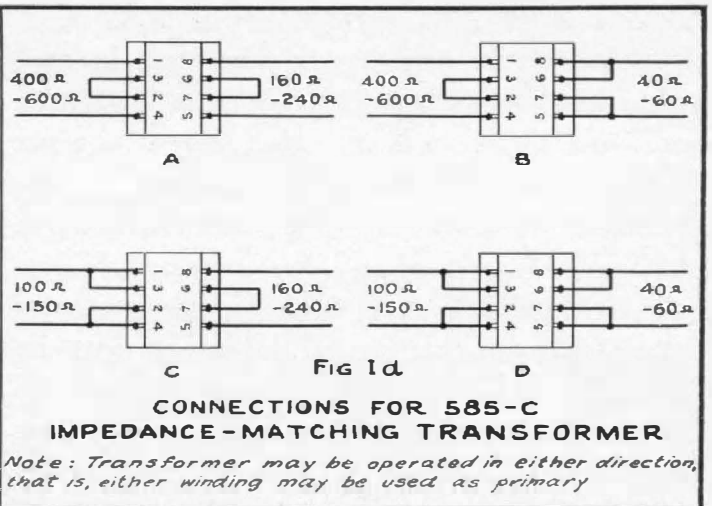
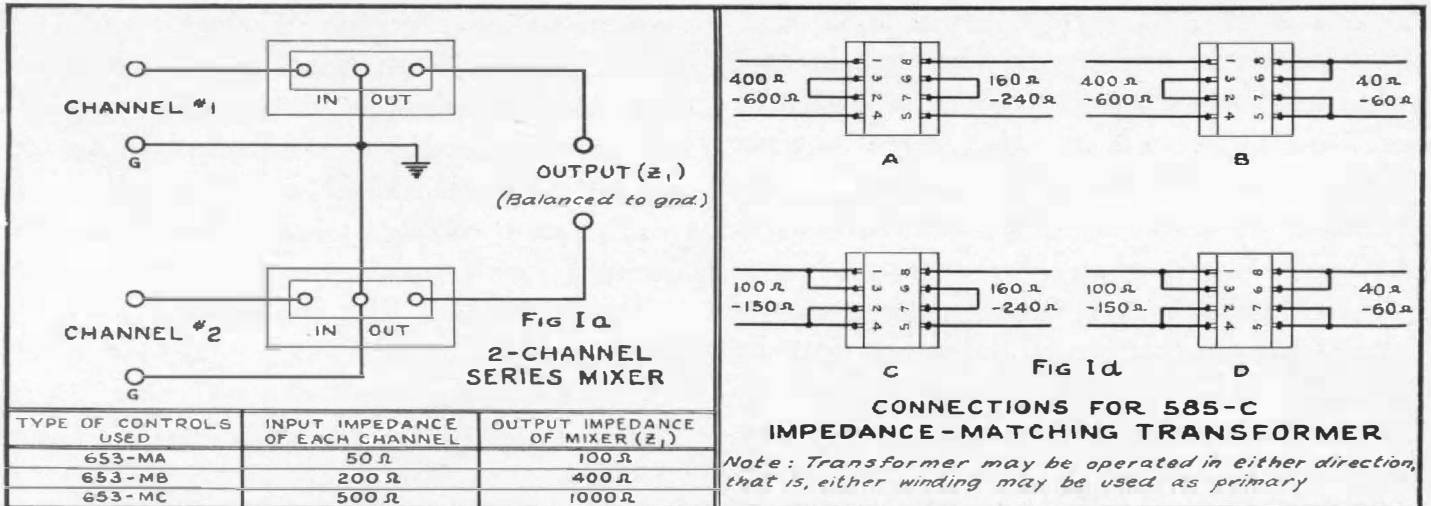

FIGURE I CONVENTIONAL MIXER CIRCUITS

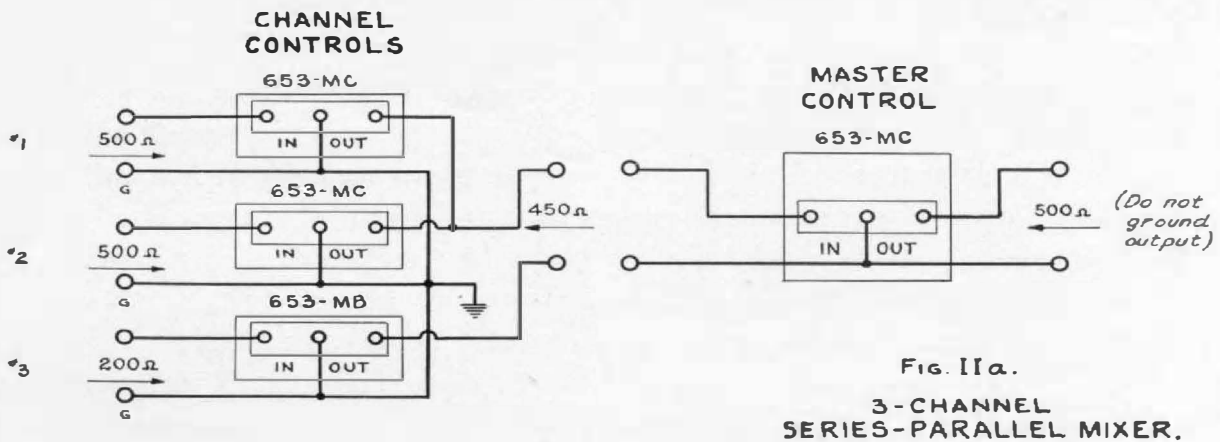

FIG. IIa.

3-CHANNEL SERIES-PARALLEL MIXER.

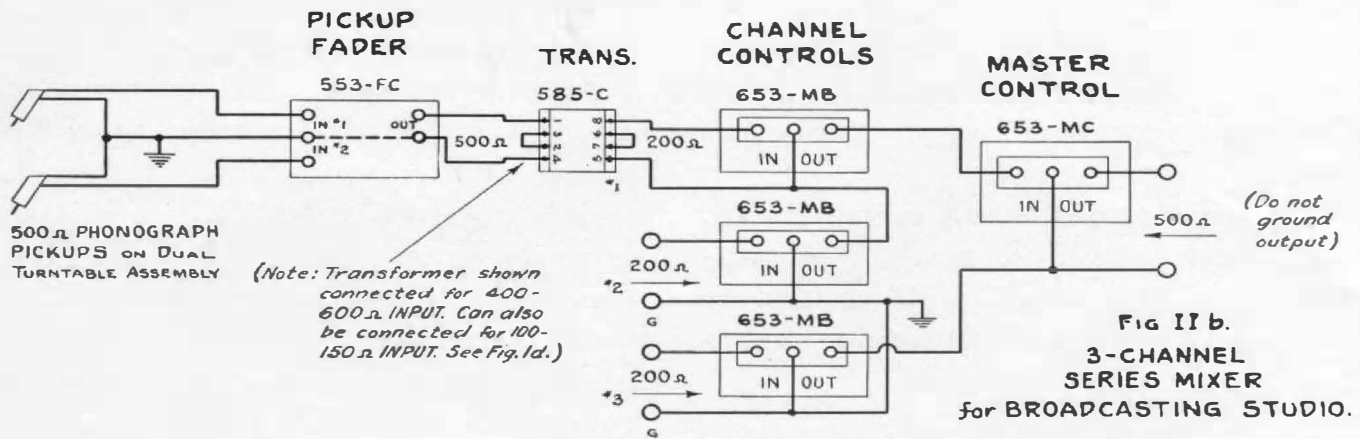

FIG. II b.

3-CHANNEL SERIES MIXER for BROADCASTING STUDIO.

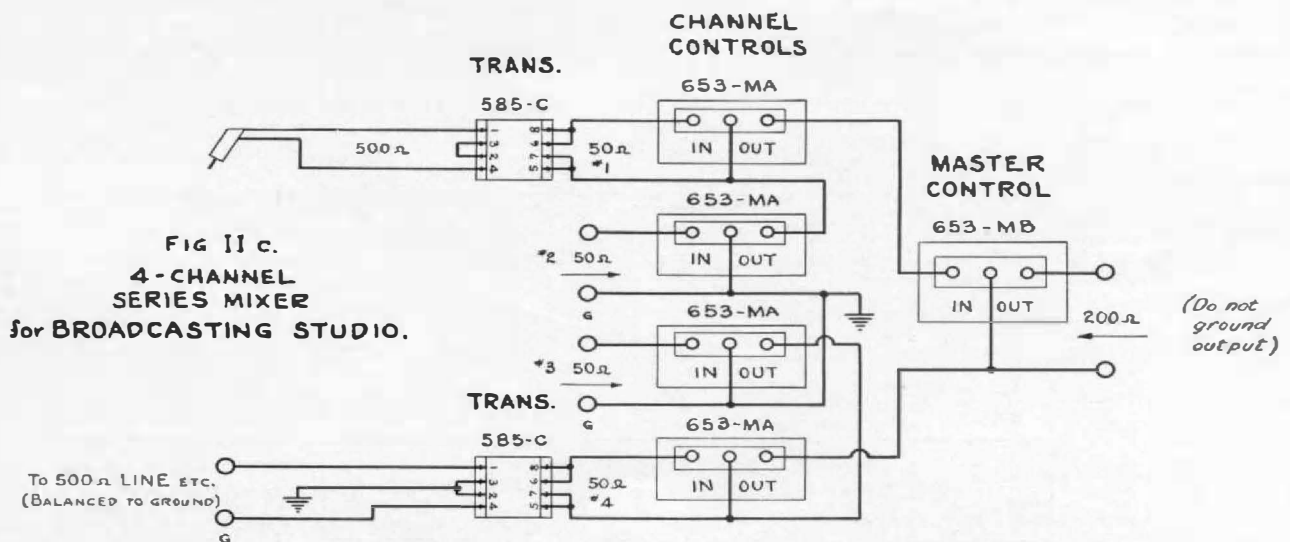

FIGURE II

SPECIAL MIXER CIRCUITS

COMMERCIAL NOISE MEASUREMENT

INEXPENSIVE noise-measuring equipment is needed by machinery manufacturers to ascertain the amount of disturbance caused by their products and by acoustical engineers and manufacturers of sound-proofing materials to demonstrate the effectiveness of sound-proofing installations.

The General Radio Company has developed a low-priced noise meter to meet exactly these commercial needs. The TYPE 559-A Noise Meter contains in one unit all of the required equipment and compares favorably in performance with instruments costing many times as much.

Figures 1 and 2 show, respectively, the appearance and method of operation of this new noise meter. It contains a special dynamic noise-

*It is not claimed, of course, that an inexpensive pickup device of this sort is equal in all respects to a high-priced microphone designed for broadcasting and recording. Under the acoustic conditions generally encountered, however, standing waves, reflections, etc., render comparatively negligible any small irregularities in the pickup characteristic.

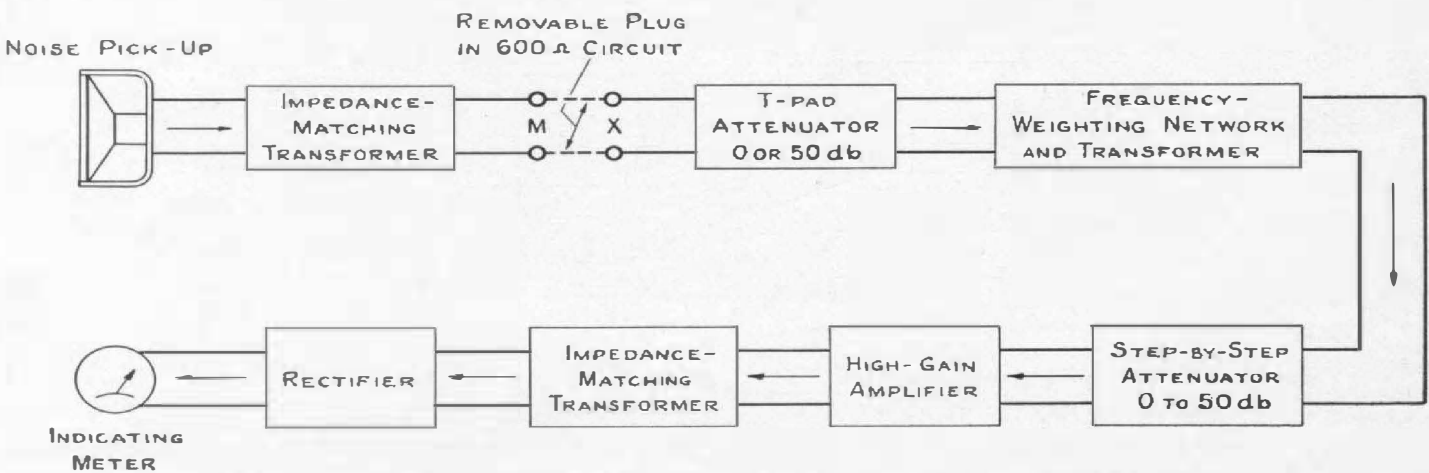

FIGURE 1. Schematic diagram of the TYPE 559-A Noise Meter

pickup unit* which is similar in construction to the usual permanent-magnet dynamic speaker and which is considerably more sensitive and rugged than the usual microphone.

An impedance matching transformer associated with the noise-pickup steps up the impedance to 600 ohms. Normally this transformer operates into a frequency-weighting network and transformer, across the output of which there is a calibrated step-by-step attenuator to adjust the input level to the amplifier. For the measurement of extremely high levels, a second attenuator of the T-pad constant-impedance type is inserted at the input of the frequency-weighting network. This additional attenuator is snapped in and out of the circuit by means of a toggle switch on the panel. Since all attenuators precede the first amplifier tube, the amplifier always operates at approximately the same level, and accordingly no error is introduced due to possible non-linearity. The output from the amplifier actuates a

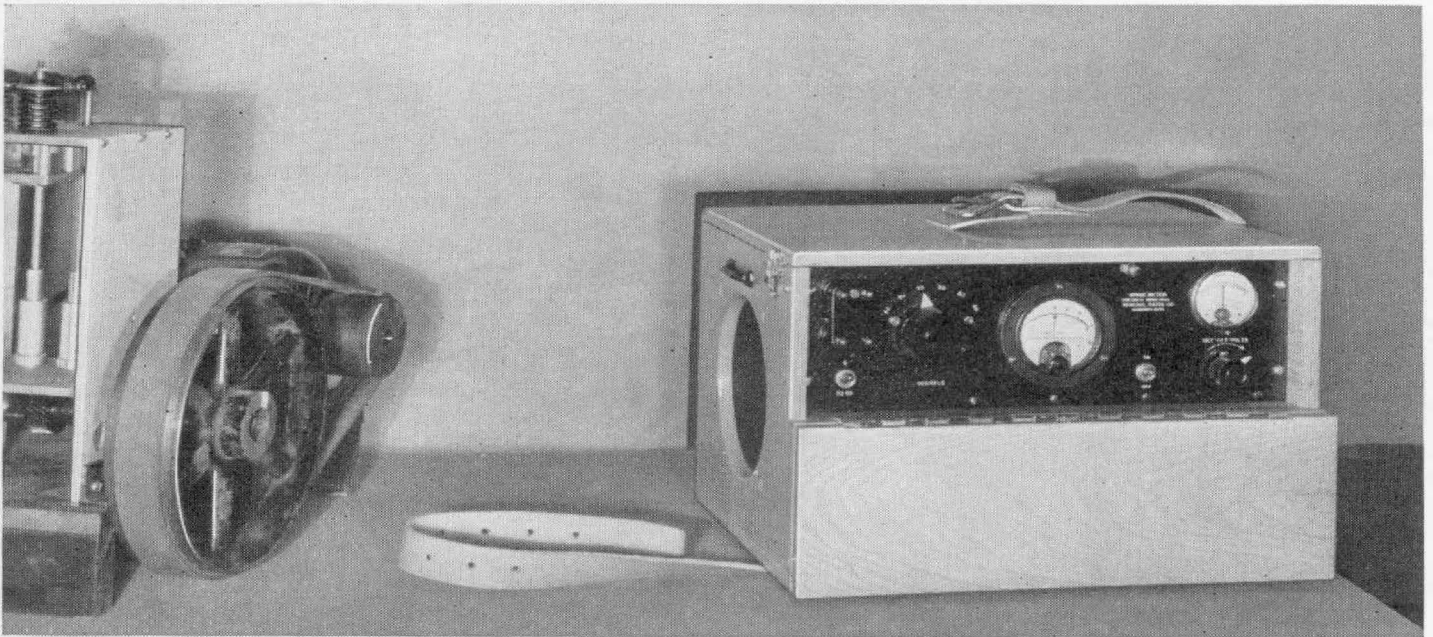

FIGURE 2. The TYPE 559-A Noise Meter is a complete, portable instrument containing the pickup unit and space for all batteries. Note the leather carrying strap

rectifier-type meter on the panel of the instrument.

The noise meter is calibrated directly in decibels above the normal threshold of hearing at 1000 cycles, and covers the range from +30 to +140 decibels. Expressed in decibels above one millibar, which is also frequently used as a reference level, this represents the range between +23 and +133 decibels.

The frequency response characteristic of the noise meter amplifier, including the frequency-weighting network, closely resembles the response of the human ear. When the self-contained dynamic pickup is used, the over-all characteristic, including the pickup, follows the same curve quite closely through the important part of the noise spectrum. If a high-quality condenser microphone with a suitable pre-amplifier is used with the noise meter, the net characteristic will be an almost ideal

approximation of the normal ear characteristic. Such precision is, however, seldom required.

Provision is made on the noise meter panel so that by removing a 4-terminal plug, the 600-ohm input circuit may be opened, allowing the connection of an external microphone or the insertion of filters for reducing or suppressing certain frequencies.

The TYPE 559-A Noise Meter is mounted in a compact, oak, carrying case which also accommodates the dynamic noise-pickup unit and all tubes and batteries. It is merely necessary to set the instrument in any desired location, turn on the switch and read the noise level directly from the panel meter and attenuator.

—H. H. SCOTT

TYPE 559-A Noise Meter, with tubes but without batteries, \$190.00. Weight, 37 lbs. without batteries. Dimensions, $16\frac{1}{2}$ x $10\frac{7}{8}$ x 12 ins. over-all.

A HIGH-VOLTAGE TWO-SECTION CONDENSER

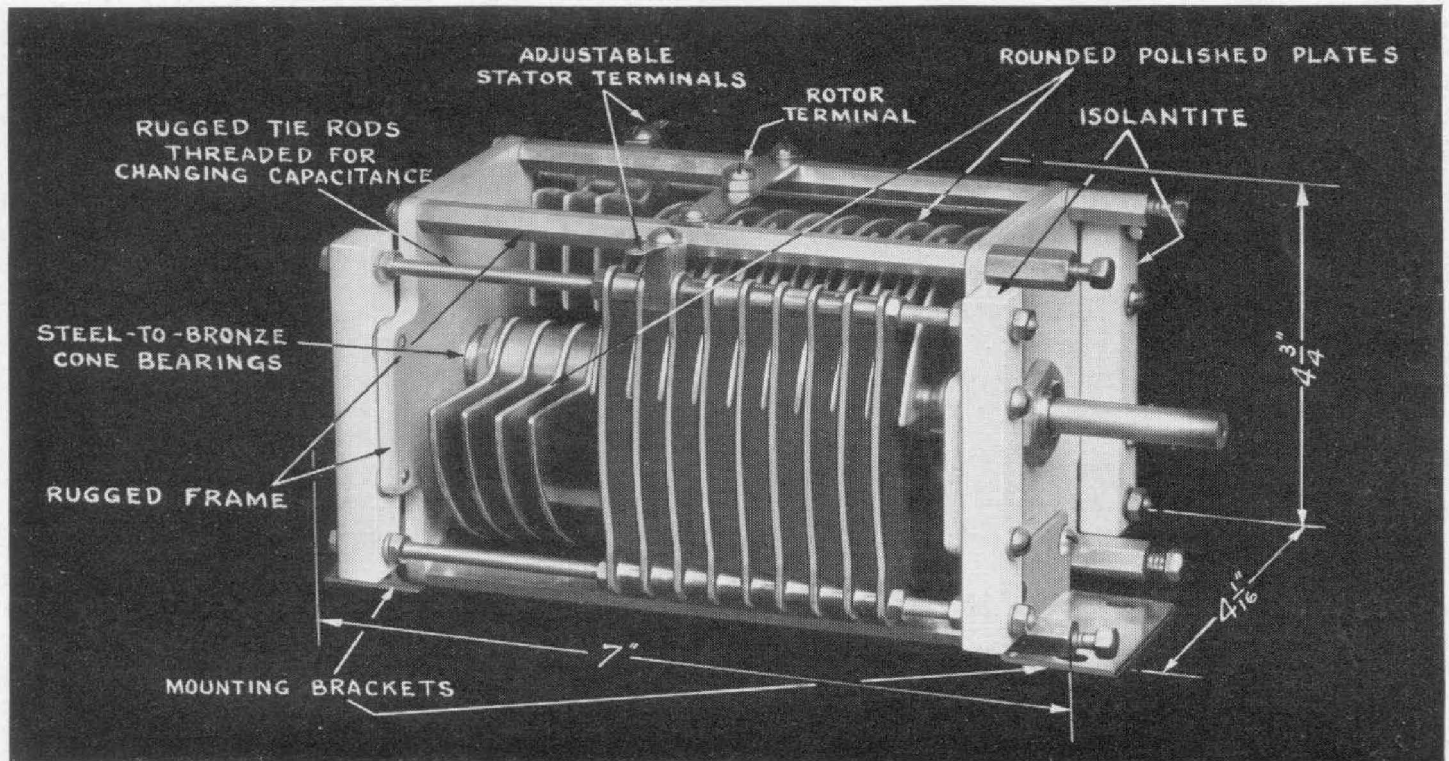

THE TYPE 639-A Variable Air Condenser has the following features:

The capacitances *per section* are readily adjusted from 25 $\mu\mu f$ to 305 $\mu\mu f$. Used as a single-section condenser the maximum capacitance is 330 $\mu\mu f$ and the minimum is 25 $\mu\mu f$.

It is conservatively rated at 3500 volts, direct current.

Its low losses are due to the use of:

1. thick aluminum plates with all edges rounded and highly polished, minimizing corona loss
2. minimum amount of dielectric placed in a weak field
3. large rotor and stator supports and spacers (resulting in low contact resistance)

4. long conical bearings

5. heavy stator terminals, positions of which are adjustable to insure uniform current distribution.

Mechanical rigidity is secured through the use of heavy aluminum end plates, large hexagonal frame supports and adequate stator rods. The shaft is of $\frac{3}{8}$ -inch steel.

For panel mounting it is supported at four points and requires no sub panel. For shelf or bread-board mounting, two large angle brackets are supplied.

Price: TYPE 639-A Variable Air Condenser, \$15.00.



GENERAL RADIO COMPANY
30 State Street - Cambridge A, Massachusetts